

RAYTOOLS



.....8Span <</MCID

RAYTOOLS

provide

•

RAYTOOLS

|

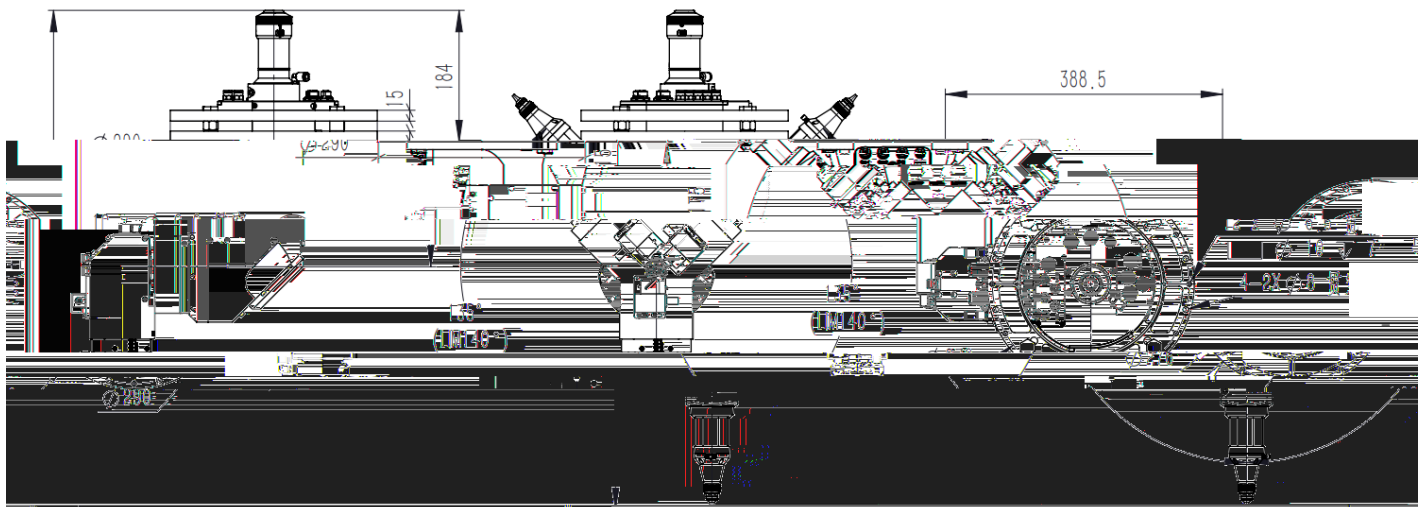

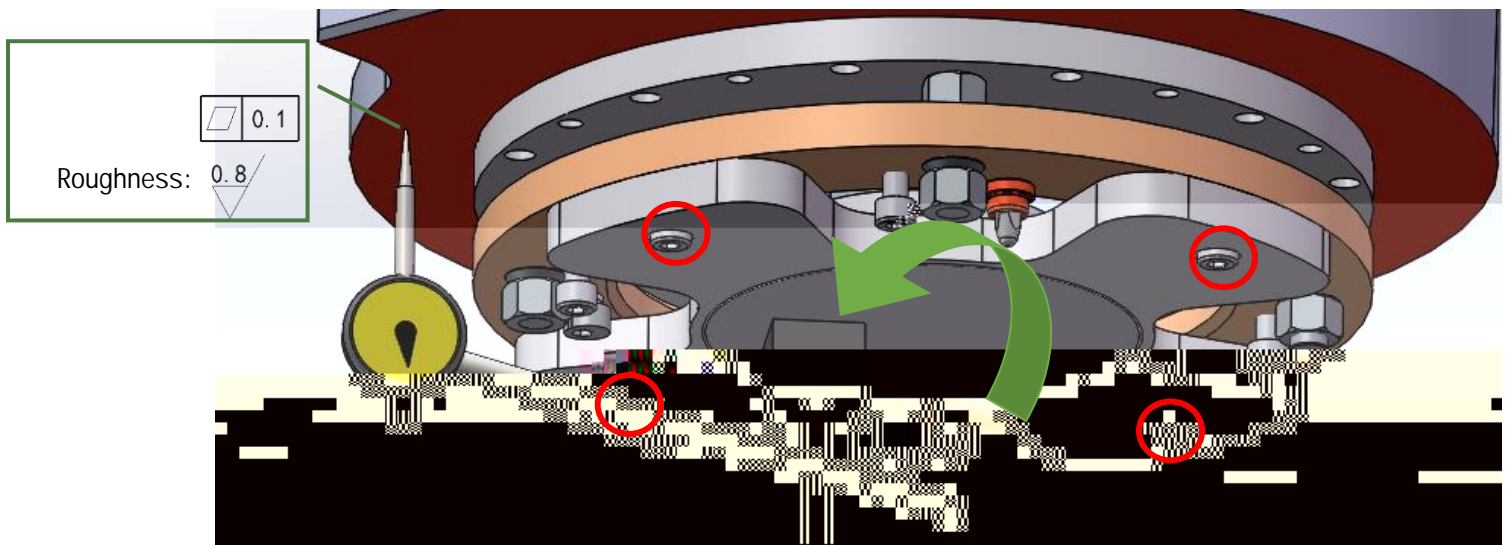
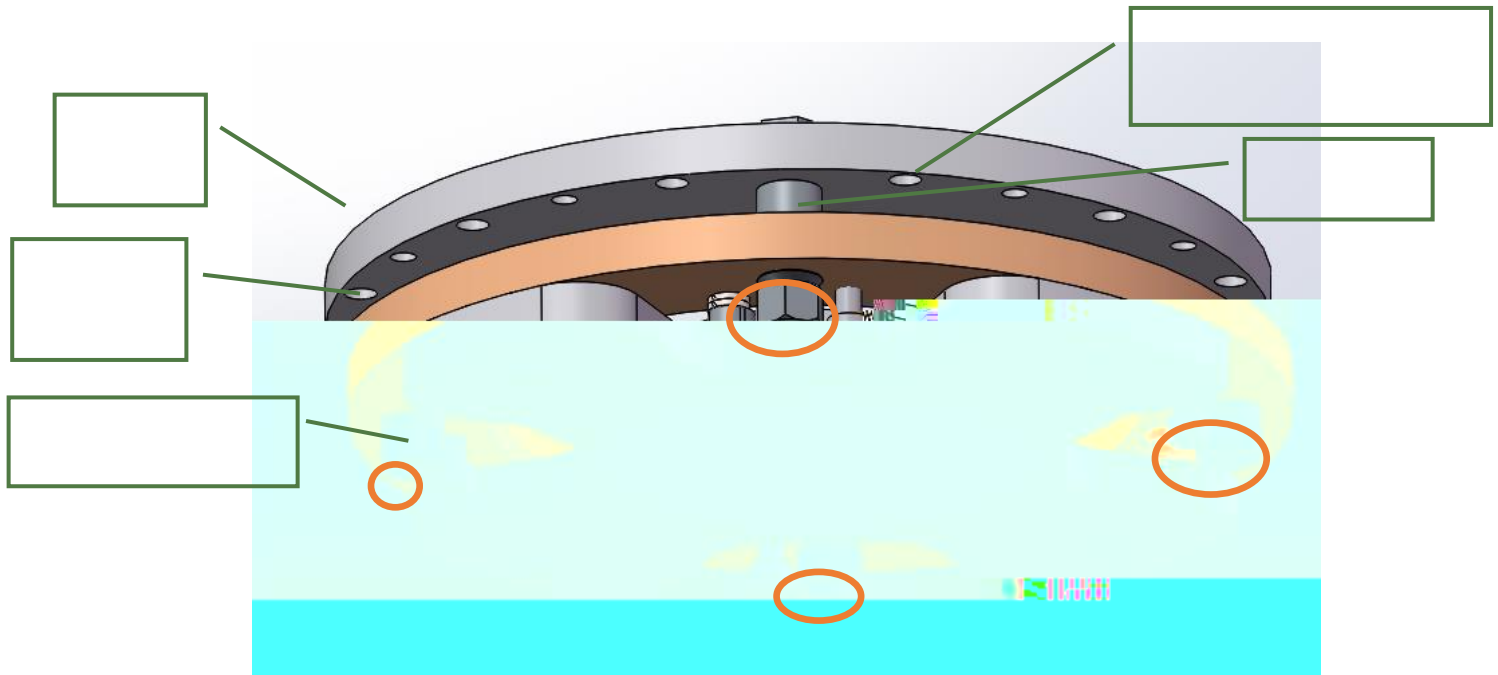

◦ ±

±



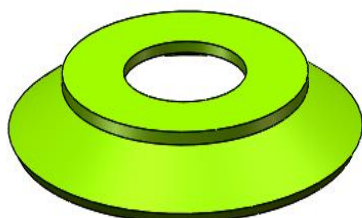
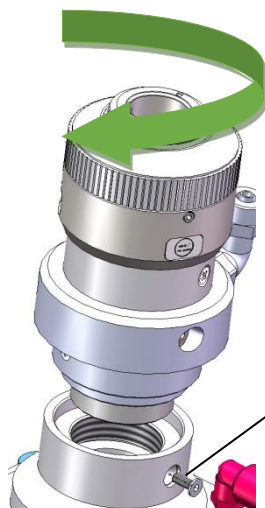

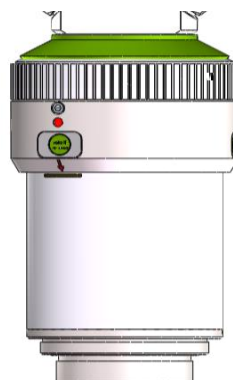
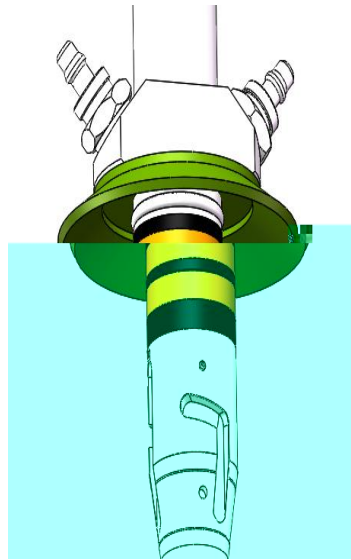

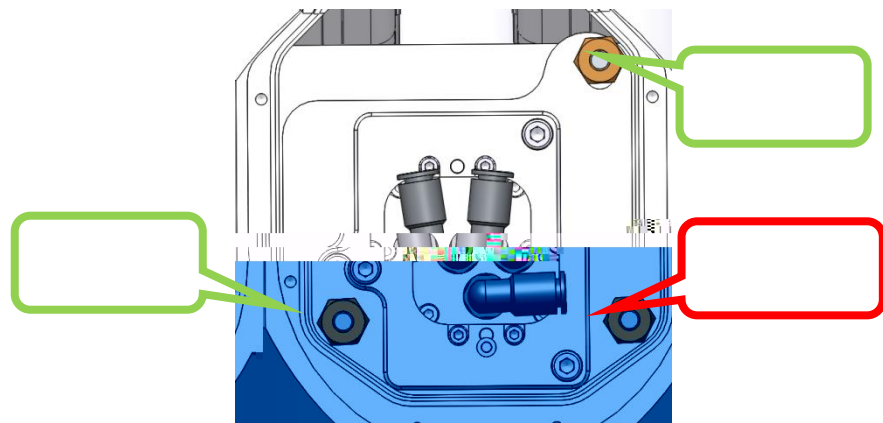

orrection

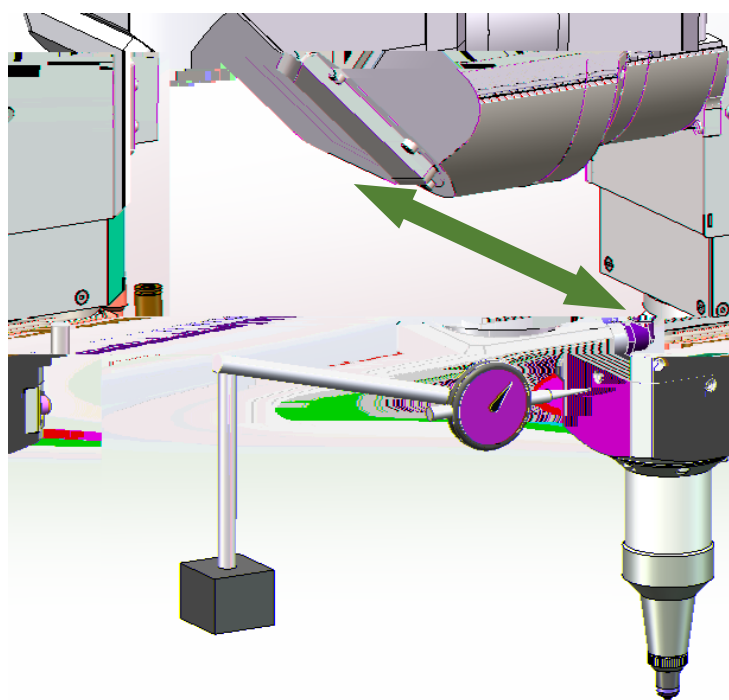

o

±

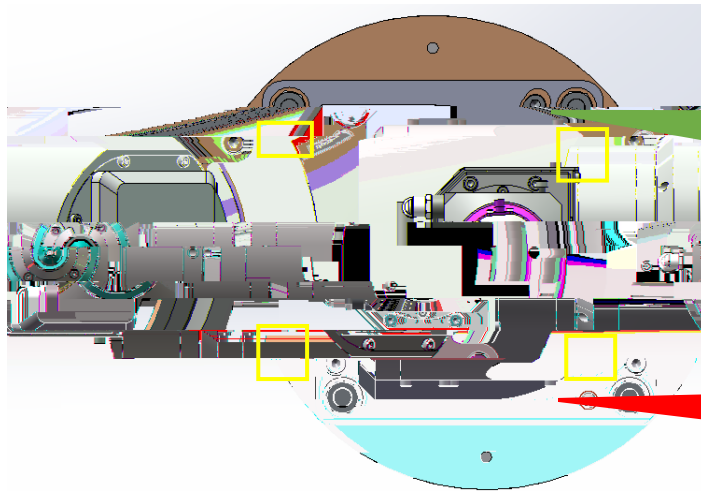

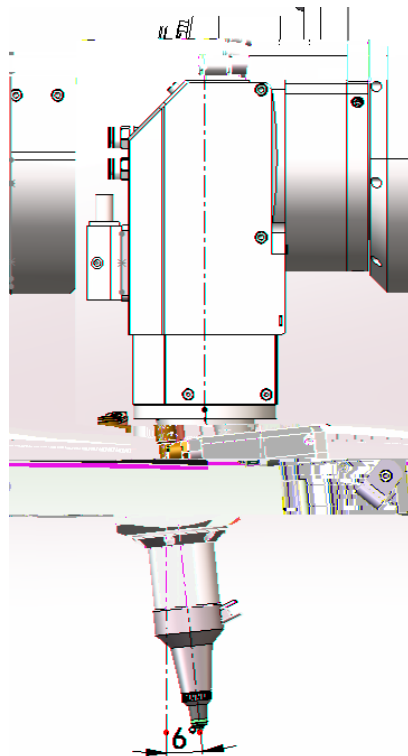



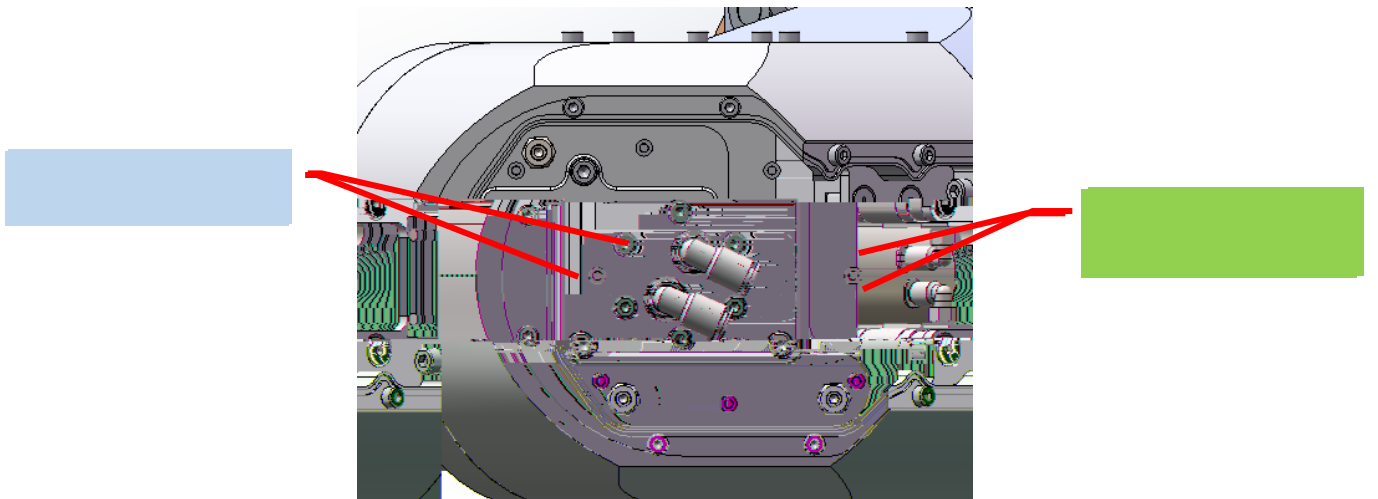
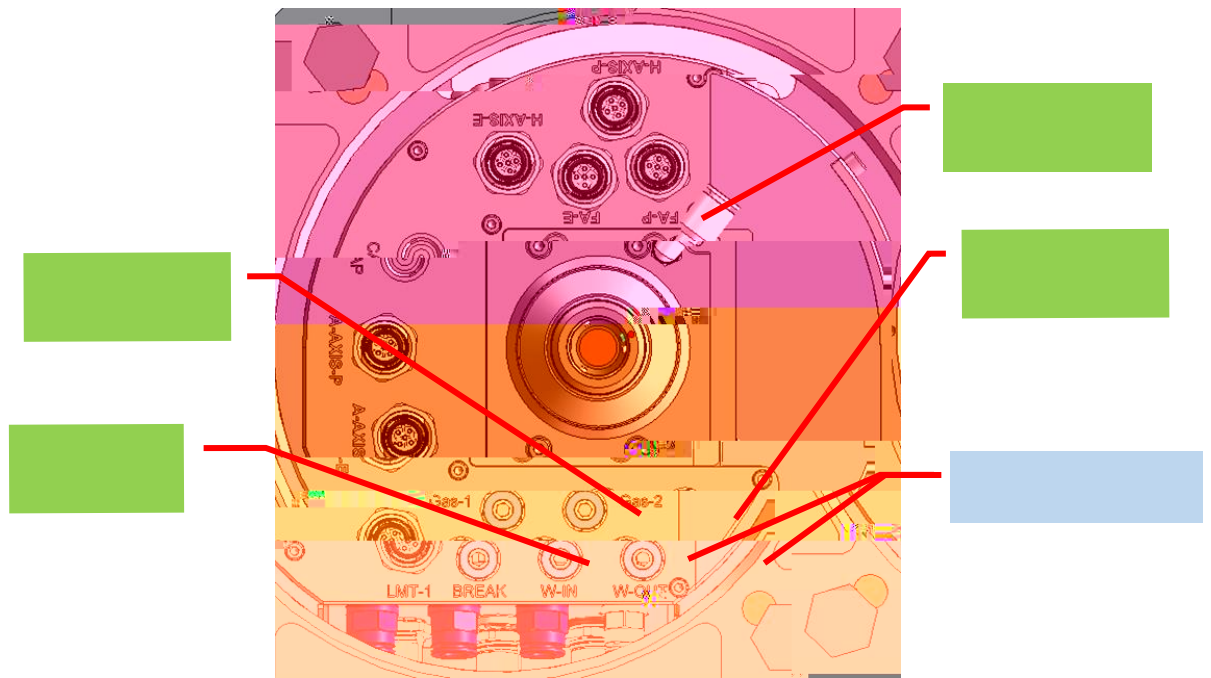

RAYTOOLS

		°		
				Ω

①

②

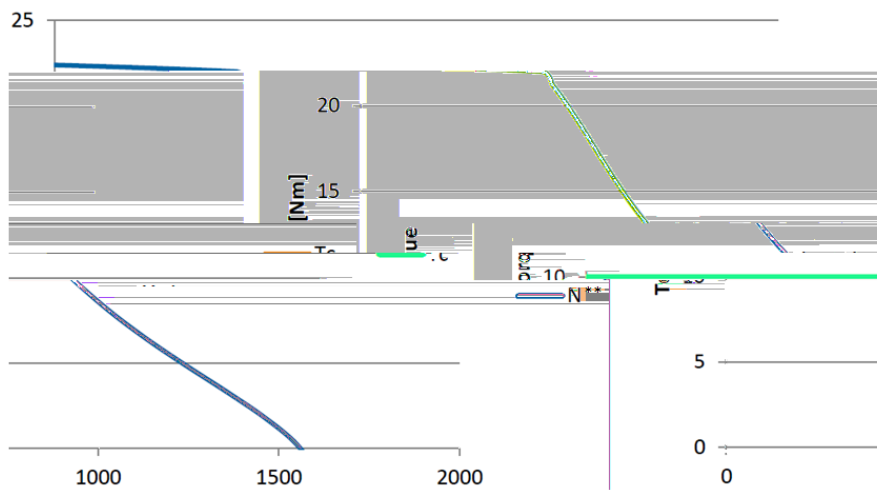

RAYTOOLS

		o			
					Ω

①

②

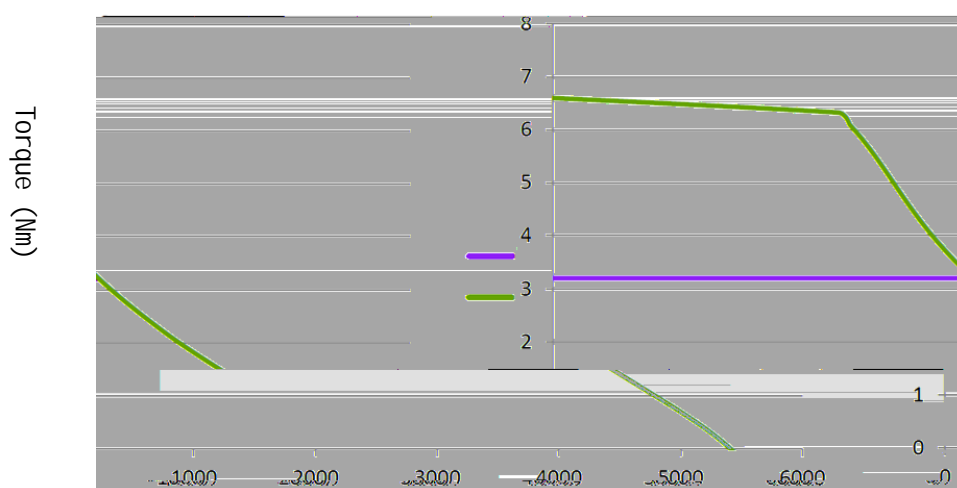

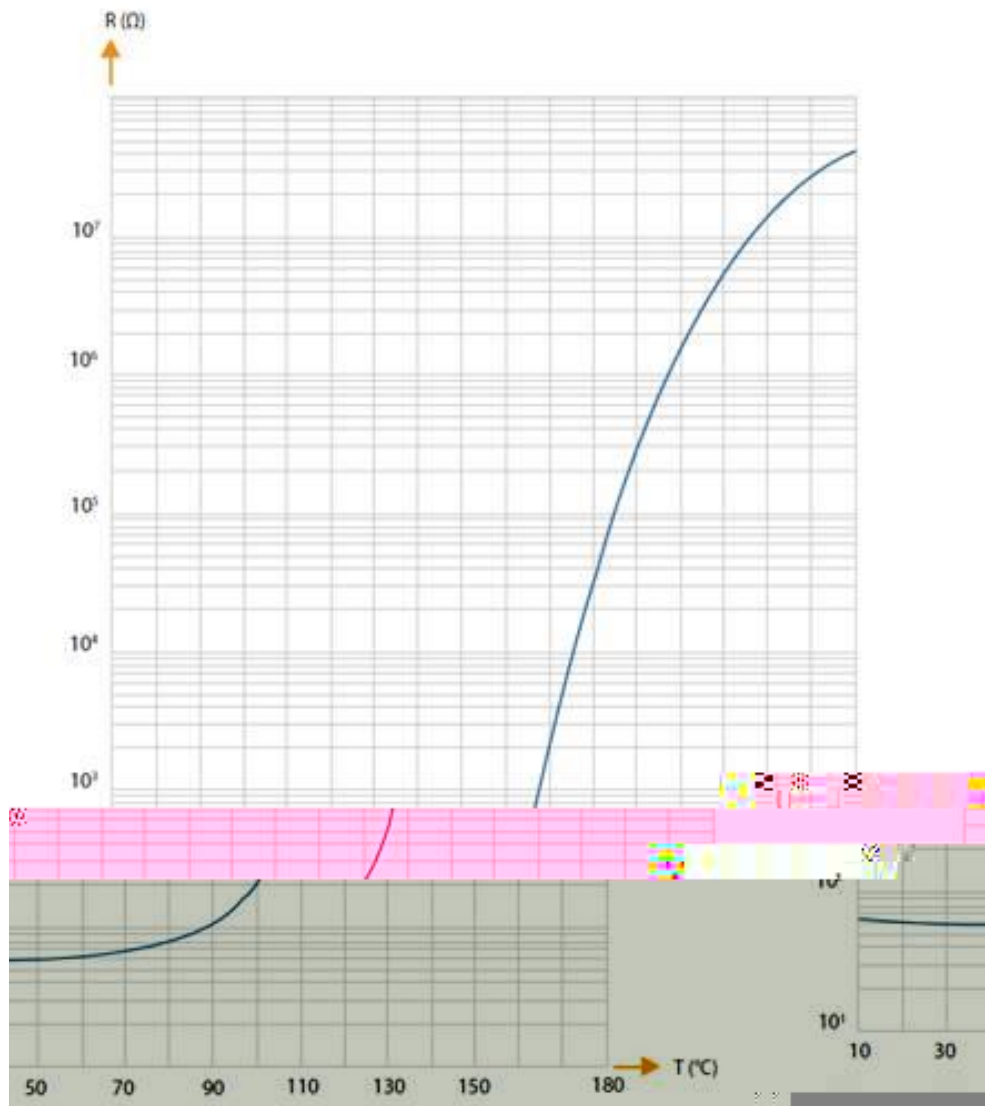



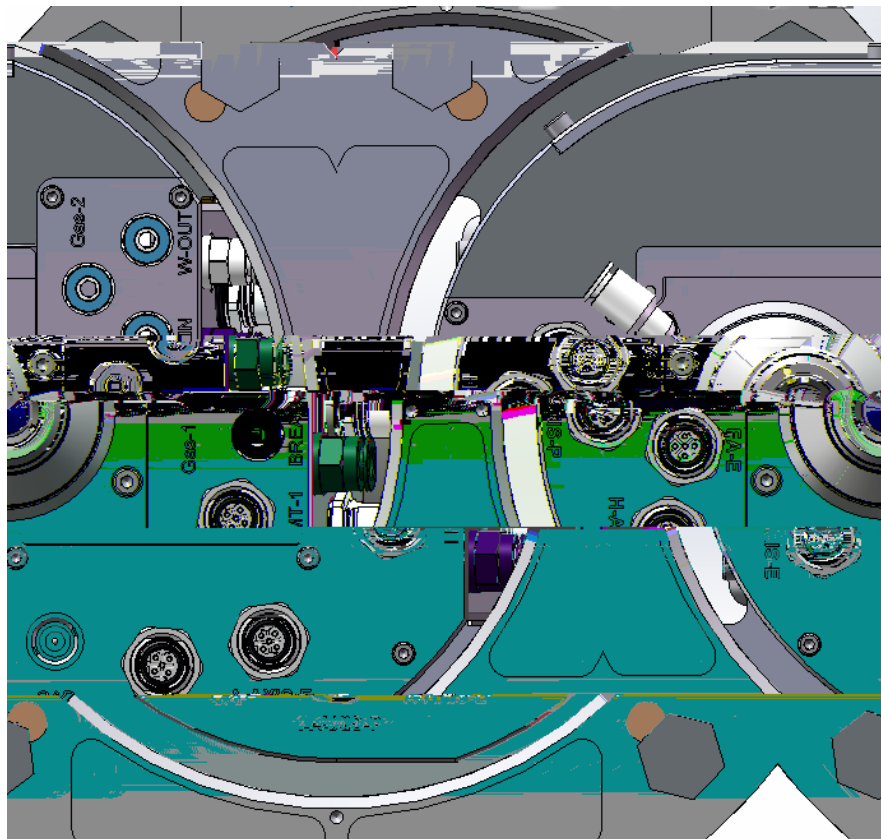

-
-
-
-



-
-
-
-

 	 	

RAYTOOLS

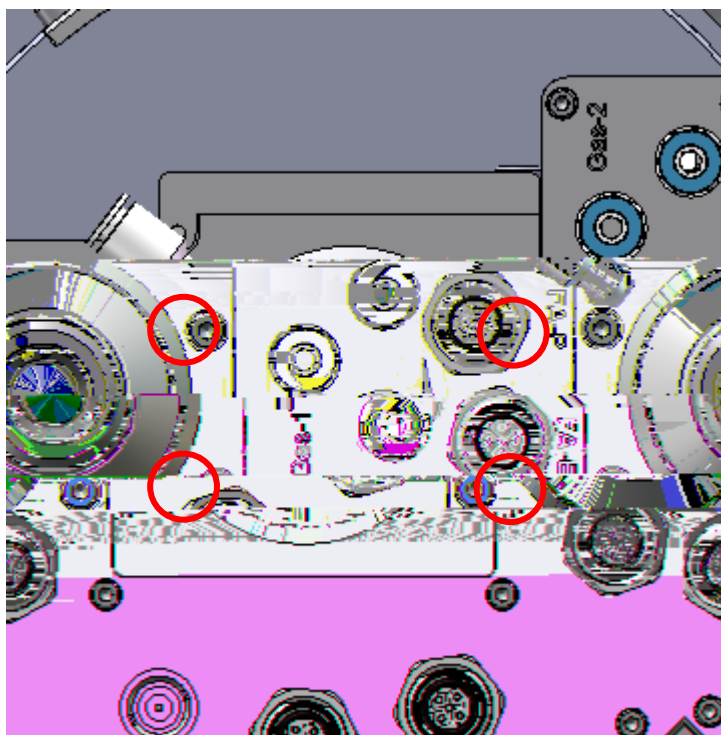

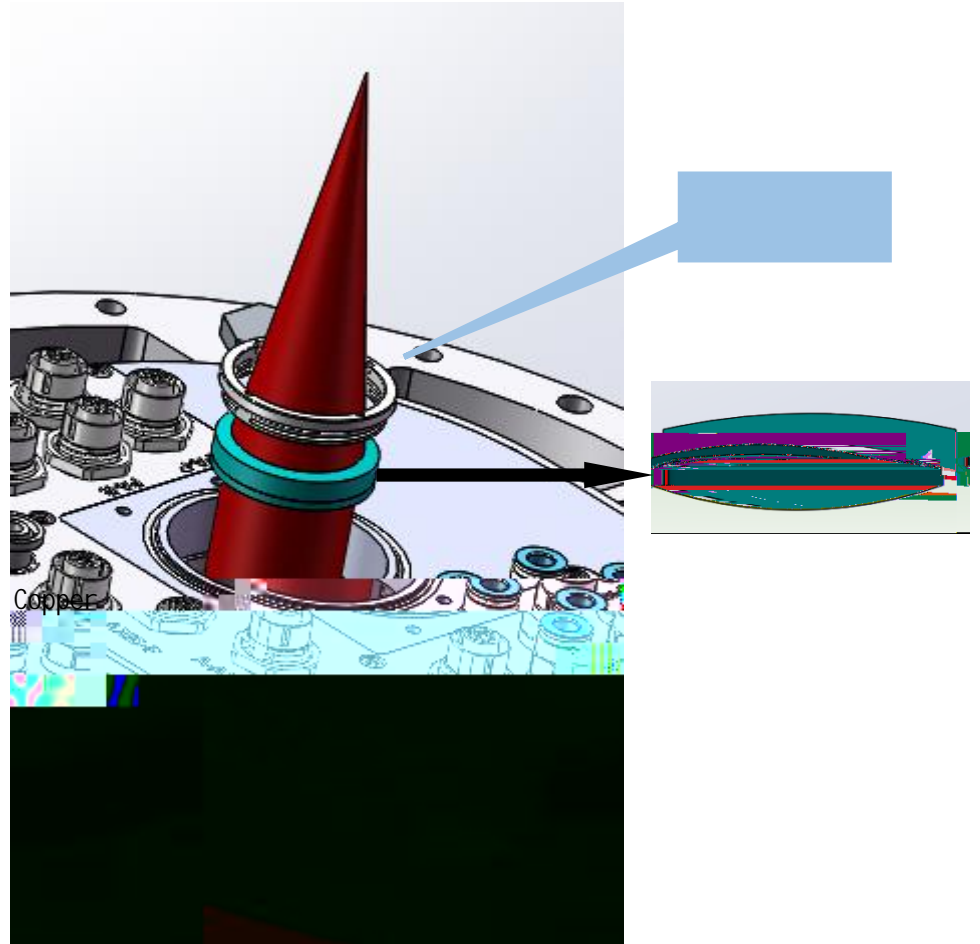

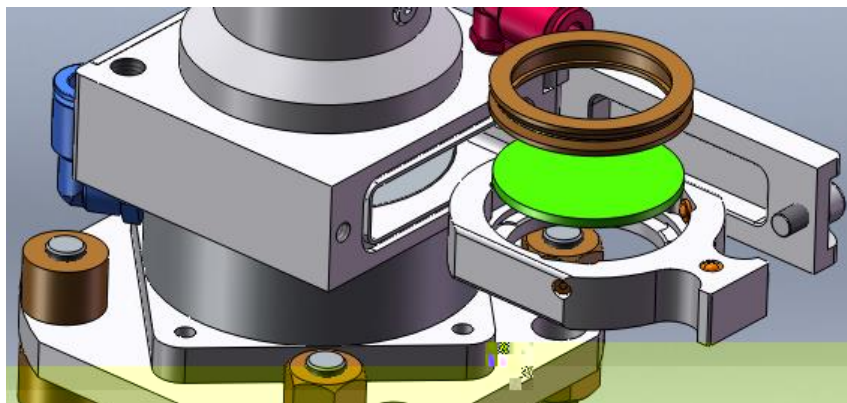

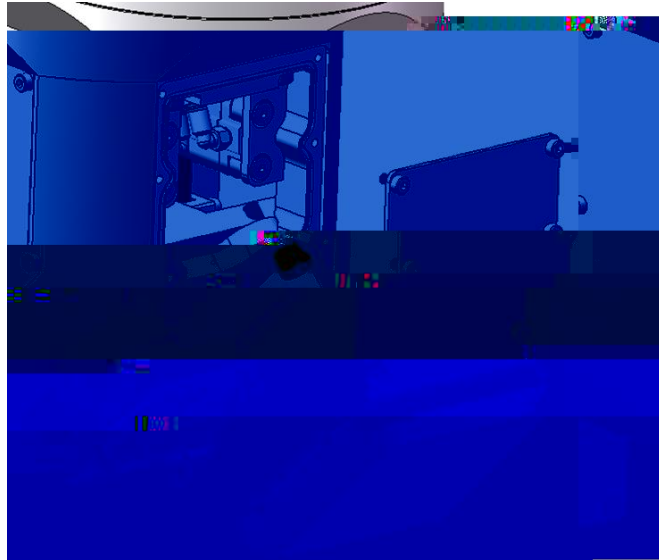

bolt

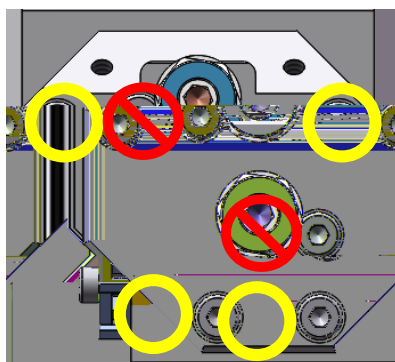
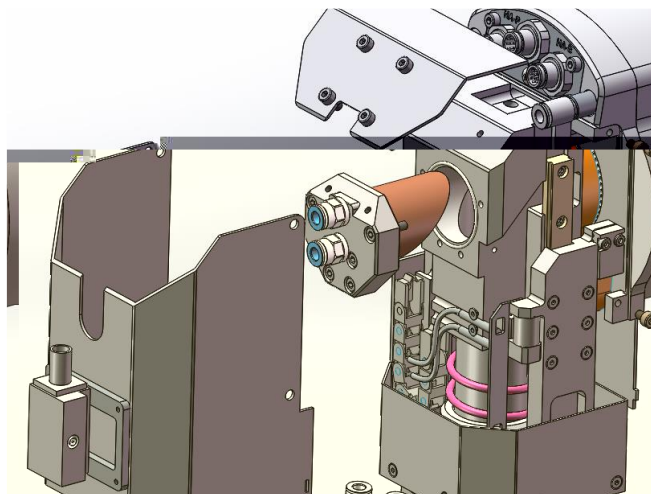

fixing

RAYTOOLS

